

Kurz- und Langdreher / Tour à poupée mobile avec ou sans canon

Citizen L₂₀ IX / X / XII

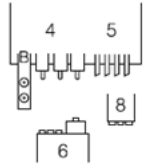

Max. Bearbeitungsdurchmesser Diamètre de tournage maxi	Ø 20 mm [25 mm]
Anzahl Achsen Nombre d'axes	IX: 6 / X: 6 / XII:7
Anzahl Werkzeuge Nombre des outils	25-34 
Max. Bearbeitungslänge Longueur de tournage maxi	50 / 200 mm
Steuerung Commande	Mitsubishi Meldas M70
Drehzahl Haupt-/Gegenspindel Nombre de tours de broche principale et de reprise	10'000 min ⁻¹ / 8'000 min ⁻¹
Drehzahl angetriebene Werkzeuge Nombre de tours des outils entraînés	6'000 min ⁻¹ / 7'500 min ⁻¹

L20 type IX configuration

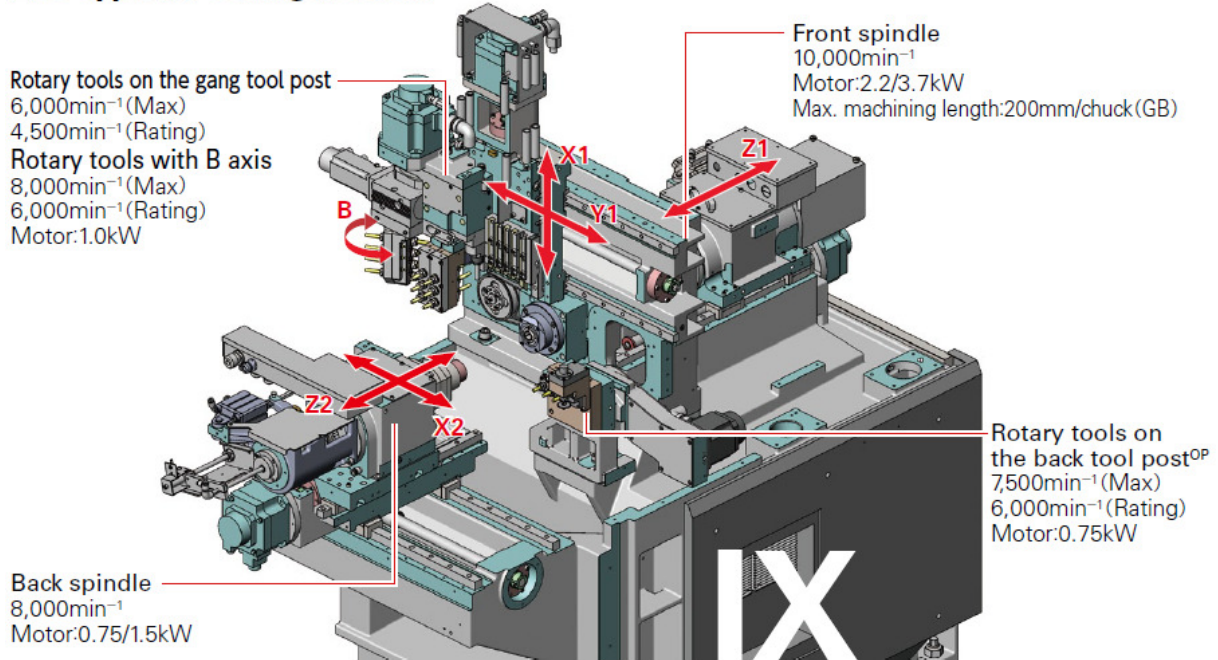

L20 type X configuration

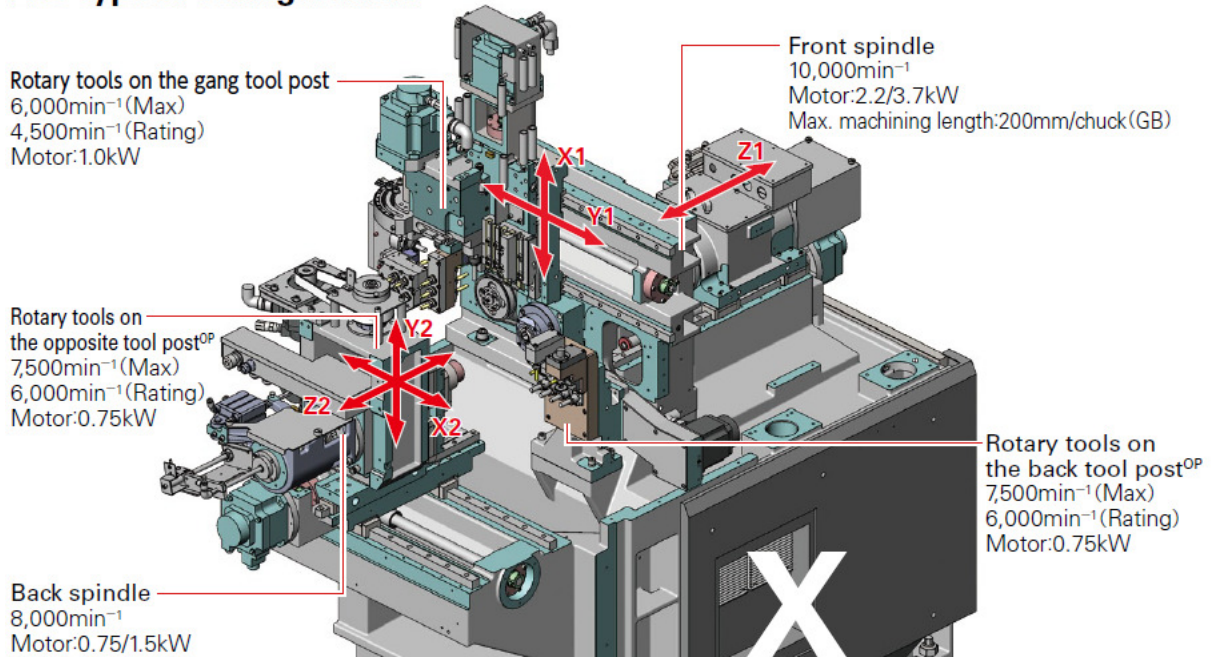

L20 type XII configuration

Rotary tools on the gang tool post
 6,000min⁻¹ (Max)
 4,500min⁻¹ (Rating)
 Rotary tools with B axis
 8,000min⁻¹ (Max)
 6,000min⁻¹ (Rating)
 Motor: 1.0kW

Front spindle
 10,000min⁻¹
 Motor: 2.2/3.7kW
 Max. machining length: 200mm/chuck (GB)

Rotary tools on the opposite tool post^{OP}
 7,500min⁻¹ (Max)
 6,000min⁻¹ (Rating)
 Motor: 0.75kW

Rotary tools on the back tool post^{OP}
 7,500min⁻¹ (Max)
 6,000min⁻¹ (Rating)
 Motor: 0.75kW

Back spindle
 8,000min⁻¹
 Motor: 0.75/1.5kW

